

Signal lights
Series SL-x-TRIO IOLINK



Piezo
transducer

Self-
diagnosis

Configurable
flashing
frequency

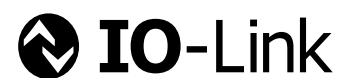

Signal lights

Series SL-x-TRIO IOLINK



The **SL-x-TRIO IOLINK** signal lights series is designed for frontal mounting with two M6 hexagon socket head cap screws (DIN ISO 4762). As a result, these signal lights can be integrated with ease in profile systems with a T-slot.

The sturdy aluminium housing and shock-resistant polycarbonate optic can withstand severe industrial conditions. Specially developed for LED applications, the polycarbonate diffuser ensures a homogeneous light-emitting surface and a high degree of efficiency.



With an IO link interface, these intelligent signal lights ensure that you know how your transducer is functioning at all times. Conventional manual function tests (lamp tests) are dispensed with.

In addition, you can parameterise the colours and signal functions and the frequency and tone intervals of the integrated piezo buzzer at any time for these signal lights via the IO link interface.

TECHNICAL DATA

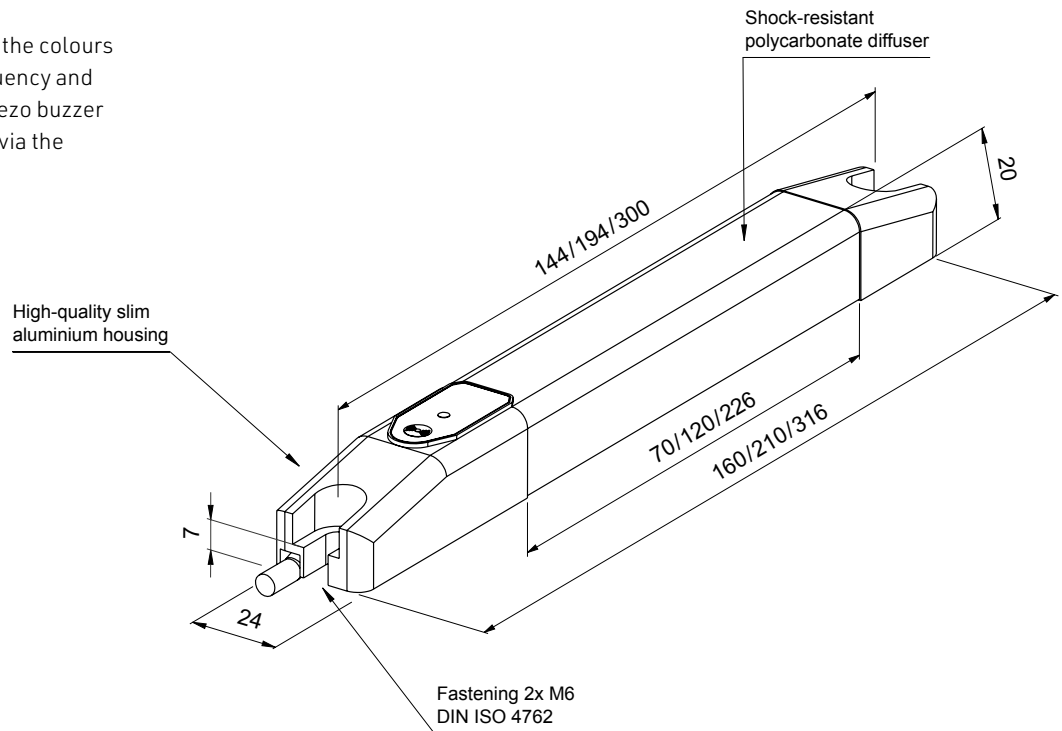
- Operating voltage 20–30 V DC
- Max. ambient temperature 50° C
- IO link interface COM 2
- Connection with 3 m PVC / PVC cable or M12 connector
- Shock-resistant polycarbonate diffuser for homogeneous signal surface
- High shock resistance: No internal oscillators and inductances sensitive to shock
- Integrated LED current and buzzer current monitor with error event output
- Parameterisable via IO link:
 - 24-bit RGB color table
 - Permanent function, flashing frequency and interpulse period, dimming, signal color
 - Buzzer frequency 2,500–4,000 Hz
 - Continuous tone, interpulse period and audio signal
 - Dimming 0–100%
- Protection class IP 54, protection class 3



Type	Part no.	Power consumption max. (mA)	Dimensions L x W x H (mm)	GTIN / EAN
Version with M12 connector 				
SL-05-TRIO IOLINK M12	11359	70	160 x 24 x 20	4262388142895
SL-1-TRIO IOLINK M12	11352	130	210 x 24 x 20	4262388142840
SL-2-TRIO IOLINK M12	11353	200	316 x 24 x 20	4262388142857
Version with 3 m PVC / PVC cable 				
SL-05-TRIO IOLINK LC	11358	70	160 x 24 x 20	4262388142888
SL-1-TRIO IOLINK LC	11354	130	210 x 24 x 20	4262388142864
SL-2-TRIO IOLINK LC	11355	200	316 x 24 x 20	4262388142871