

Machine tool lights  
Series WML-x-UF  
Series WML-x-UFR



Flat  
design

Reverse side  
cable outlet

Completely  
casted

# Machine tool lights

## Series WML-x-UF

The lamps series for tooling machines WML-x-UF with compact and very flat dimensions allows easy mechanical integration into machines with limited space. A simple electrical installation directly to 24 V DC is possible with M12 plug connector systems.

The **robust aluminum housing with stainless steel fender** and a **thermally tempered glass front** protects the LED light in front of numerous chemicals such as alkalis, acids and oils and flying hot chips bombardment in machine tools.



The series WML-x-UF are available with M12 connector or with 5 m PUR / PVC cable with open end (\* LC-types). By the **very flat design** a space-saving installation and mounting in ceilings or doors without corresponding metal cutout is possible.

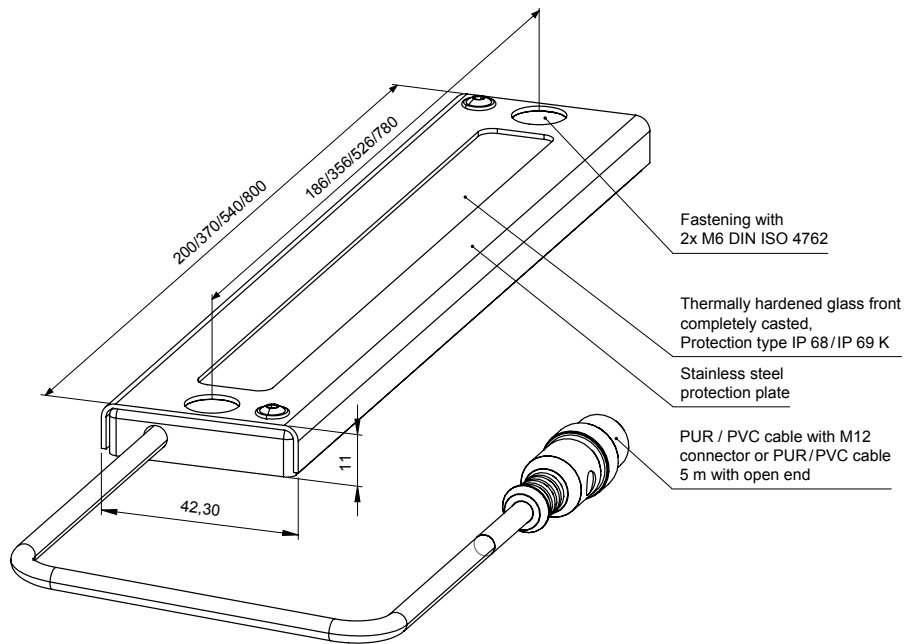

### TECHNICAL DATA

- Operating voltage 21–27 V DC
- Connection with M12 connector plug / 250 mm PUR / PVC cable or 5 m PUR / PVC cable with open end
- Remote control and dimming with switching signal (PWM)
- Resistant to impacting or vibration
- Thermally hardened glass front
- Robust aluminum housing with stainless steel protection plate
- Completely casted with a transparent PUR encapsulation
- Integrated overvoltage and temperature protection
- Compact, particularly flat design
- Flicker-free illumination in daylight quality, color temperature 5,700 K, Ra ≥ 90
- Max. ambient temperature 50° C
- IP 68 / IP 69 K protection class (DIN 40050-9:1993), protection class 3



Type	Part no.	Power consumption (mA)	Illuminance (lux) 1 m	Dimensions L x W x H (mm)	GTIN / EAN
Version with M12 connector 					
WML-6-UF M12	10296	270	230	200 x 42.3 x 11	4262388141805
WML-12-UF M12	10287	540	460	370 x 42.3 x 11	4262388141768
WML-18-UF M12	10283	800	600	540 x 42.3 x 11	4262388141744
WML-24-UF M12	10284	1,100	900	540 x 42.3 x 11	4262388141751
WML-36-UF M12	10295	1,600	1,100	800 x 42.3 x 11	4262388141799
Version with 5 m PUR / PVC cable 					
WML-6-UF LC	10300	270	230	200 x 42.3 x 11	4262388141829
WML-12-UF LC	10299	540	460	370 x 42.3 x 11	4262388141812
WML-18-UF LC	10288	800	600	540 x 42.3 x 11	4262388141775
WML-24-UF LC	10289	1,100	900	540 x 42.3 x 11	4262388141782
WML-36-UF LC	10301	1,600	1,100	800 x 42.3 x 11	4262388141836

# Machine tool lights

## Series WML-x-UFR

The compact dimensions of the machine tools series WML-x-UFR allow an easy integration into machines and cutting machines without significantly restricting the space. On account of the cable outlet on the reverse in combination with the flat construction of the housing a bigger cutting in the metal plate is no longer necessary.



The **robust aluminum housing with stainless steel protection plate** and a **thermally hardened glass front** protect the lamp against a lot of chemicals such as alkalis, acids, oils and hot chippings in machine tools. The lights are completely casted.

The machine tool lights of the series WML-x-UFR are available with either M12 connector or with 5 m PUR / PVC cable with open end (\*LC version).

### TECHNICAL DATA

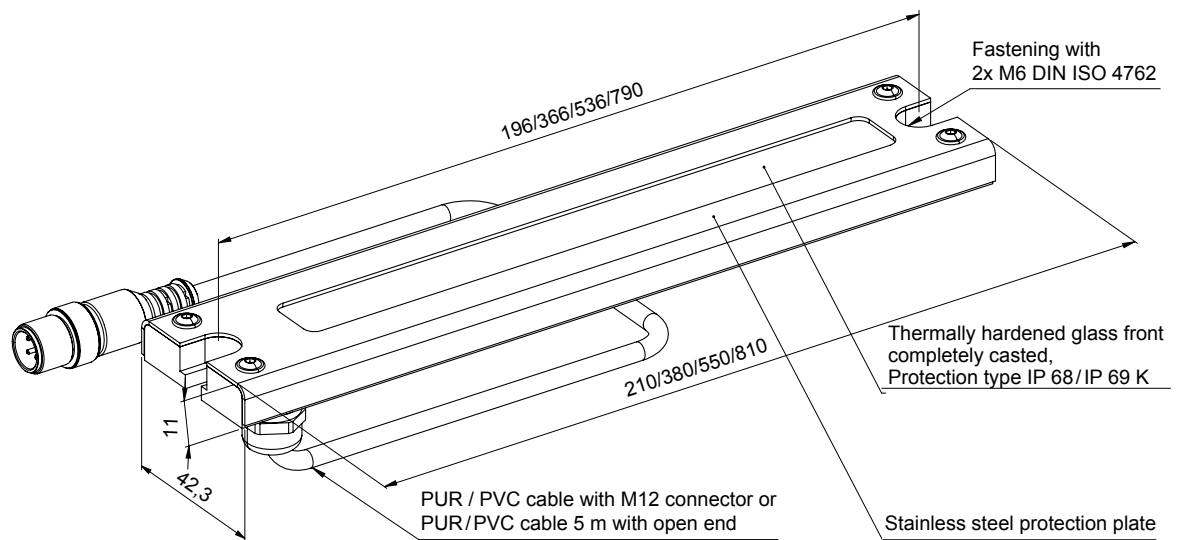
- Operating voltage 21–27 V DC
- Light colour: daylight white
- Color rendering index: 5,700 K
- Color rendering index: Ra ≥ 90
- Max. ambient temperature 50° C
- IP 68 / IP 69 K protection class, protection class 3



Type	Part no.	Power consumption (mA)	Illuminance (lux) 1 m	Dimensions L x W x H (mm)	GTIN / EAN
Version with M12 connector 					
WML-6-UFR M12	11179	270	230	210 x 42.3 x 11	4262388142086
WML-12-UFR M12	11181	540	460	380 x 42.3 x 11	4262388142109
WML-18-UFR M12	11183	800	600	550 x 42.3 x 11	4262388142123
WML-24-UFR M12	11185	1,100	900	550 x 42.3 x 11	4262388142147
WML-36-UFR M12	11187	1,600	1,100	810 x 42.3 x 11	4262388142161
Version with 5 m PUR / PVC cable 					
WML-6-UFR LC	11180	270	230	210 x 42.3 x 11	4262388142093
WML-12-UFR LC	11182	540	460	380 x 42.3 x 11	4262388142116
WML-18-UFR LC	11184	800	600	550 x 42.3 x 11	4262388142130
WML-24-UFR LC	11186	1,100	900	550 x 42.3 x 11	4262388142154
WML-36-UFR LC	11188	1,600	1,100	810 x 42.3 x 11	4262388142178