

Machine lights  
Series ML-x-20



Integrated  
cut-off angle  
20°

Completely  
casted

Protection  
class  
IP 68

# Machine lights

## Series ML-x-20

The machine light allows for compact dimensions easy mechanical integration into machines without significantly restricting the space available. A simple electrical installation will be carried over directly to 24 V DC M12 Connector systems. LC types have a 5 m PUR/PVC cable with open end.

With a robust aluminum housing and a weatherproof, UV resistant and crystal clear polyurethane casting, the LED light from the environment and numerous chemicals such as alkalis, acids and oils, is protected.

The highly efficient LEDs have a beam angle of 100° and produce a homogeneous, flicker-free light.



The ML-Series are available in 5 sizes. This lights are providing space-saving mounting for top or for example door mounting.

The series ML-x-20 have an integrated dim out angle to dip the light in top position.

### TECHNICAL DATA

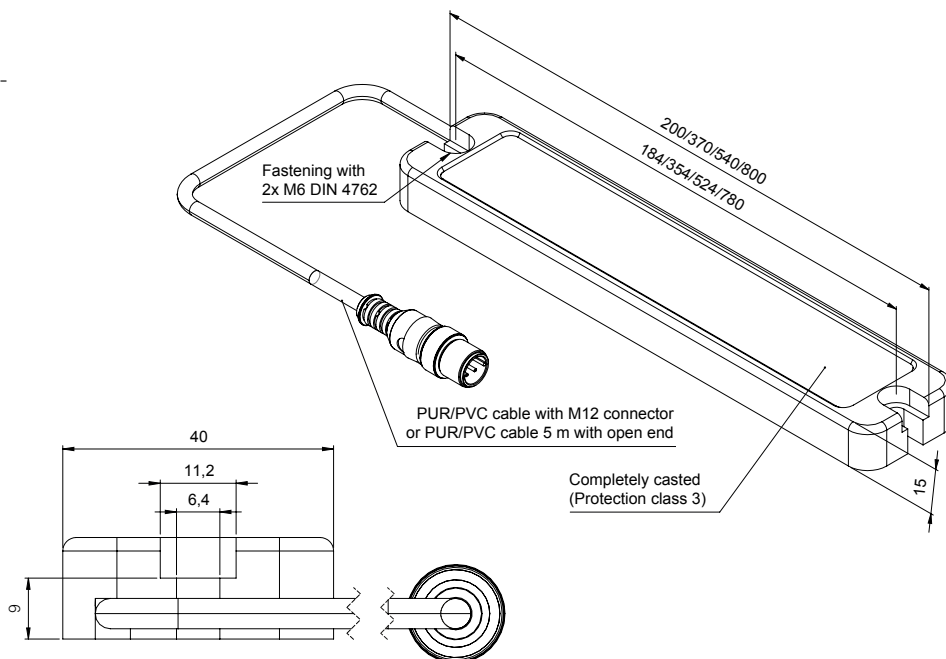
- Operating voltage 21–27 V DC
- Integrated cut-off angle 20°
- Connection with M12 connector plug /250 mm PUR/PVC cable or 5 m PUR/PVC cable with open end
- Lateral or rear cable outlet
- Remote control with 24 V signal
- Dimming with PWM signal
- Resistant to shock or vibration
- Compact, robust and flat design
- Flat aluminium housing
- Fixing with 2x hexagonal socket head screws M6/DIN 912
- Integrated overvoltage and temperature protection
- Flicker-free illumination in daylight quality, color temperature 5,700 K, Ra≥90
- Protection class IP 68, protection class 3



Type	Part no.	Power consumption (mA)	Illuminance (lux) 1 m	Dimensions L x W x H (mm)	GTIN/EAN
Version with M12 connector 					
ML-6-20 M12	10221	270	230	200 x 40 x 15	4262388140136
ML-12-20 M12	10219	540	460	370 x 40 x 15	4262388140112
ML-18-20 M12	10220	800	600	540 x 40 x 15	4262388140129
ML-24-20 M12	10251	1,100	900	540 x 40 x 15	4262388140303
ML-36-20 M12	10294	1,600	1,100	800 x 40 x 15	4262388140563
Version with 5 m PUR/PVC cable 					
ML-6-20 LC	10262	270	230	200 x 40 x 15	4262388140358
ML-12-20 LC	10226	540	460	370 x 40 x 15	4262388140143
ML-18-20 LC	10260	800	600	540 x 40 x 15	4262388140334
ML-24-20 LC	10261	1,100	900	540 x 40 x 15	4262388140341
ML-36-20 LC	10639	1,600	1,100	800 x 40 x 15	4262388140754