

Signal lights
Series SL-x-TRIO Corner IO LINK



Piezo
transducer

Self-
diagnosis

Configurable
flashing
frequency



Signal lights

Series SL-x-TRIO Corner IO LINK



The signal lights series **SL-x-TRIO Corner IOLINK** are built on the base of a system profile housing in the grid of 20 mm and slot 5. Easy installation in machines and apparatus is achieved by means of two movable slot nuts supplied.

The front optic is made of **shock-resistant and shatterproof polycarbonate**. Due to the high degree of diffusion it has a high glare suppression and a **homogenous light-emitting surface**.



With an IO link interface, these intelligent signal lights ensure that you know how your transducer is functioning at all times. Conventional manual function tests (lamp tests) are dispensed with.

In addition, you can parameterise the colors and signal functions and the frequency and tone intervals of the integrated piezo buzzer at any time for these signal lights via the IO link interface.

TECHNICAL DATA

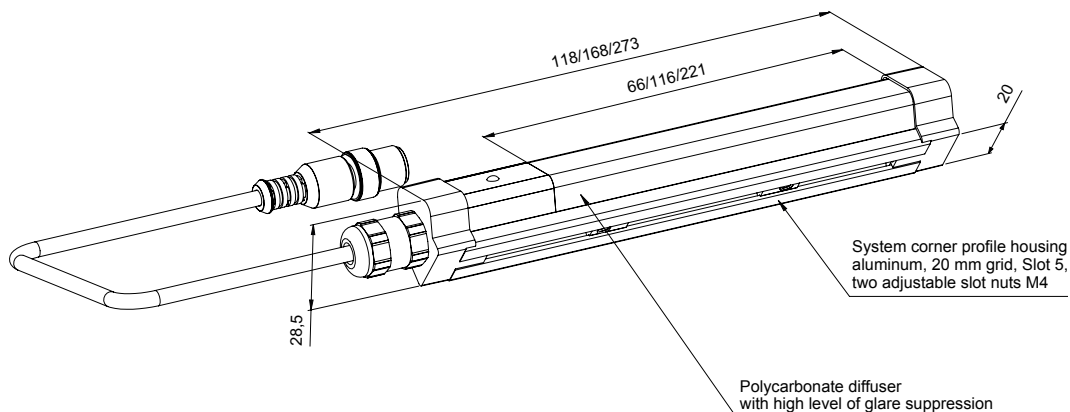
- Operating voltage 20–30 V DC
- IO link interface COM2
- Connection with 3 m PVC/PVC cable or M12 connector
- Shock-resistant polycarbonate diffuser for homogeneous signal surface
- High shock resistance: No internal oscillators and inductances sensitive to shock
- Integrated LED current and buzzer current monitor with error event output
- Parameterisable via IO link:
 - 24-bit RGB color table
 - Permanent function, flashing frequency and interpulse period, dimming, signal color
 - Buzzer frequency 2,500–4,000 Hz
 - Continuous tone, interpulse period and audio signal
 - Dimming 0–100%
- IP 54 protection class, protection class 3



Type	Part no.	Power consumption max. (mA)	Dimensions L x W x H (mm)	GTIN/EAN
Version with M12 connector 				
SL-05-TRIO Corner IOLINK M12	11362	70	118 x 28.5 x 28.5	4262388142918
SL-1-TRIO Corner IOLINK M12	11364	130	168 x 28.5 x 28.5	4262388142932
SL-2-TRIO Corner IOLINK M12	11366	200	273 x 28.5 x 28.5	4262388142956
Version with 3 m PVC/PVC cable 				
SL-05-TRIO Corner IOLINK LC	11361	70	118 x 28.5 x 28.5	4262388142901
SL-1-TRIO Corner IOLINK LC	11363	130	168 x 28.5 x 28.5	4262388142925
SL-2-TRIO Corner IOLINK LC	11365	200	273 x 28.5 x 28.5	4262388142949